



# ColdTech – Culinary Coolness

## Highlights:

- Solid, durable, three door, high grade, 300 series, stainless steel interior & exterior (except backs) providing commercial kitchens with a long-lasting, easy to clean pizza prep table.
- Digital temperature controls on the outside of the unit for easy programming.  
1° C to 6° C/33° F to 43° F
- The **ColdTech Commercial** Warranty: 3 years bumper-to-bumper & a total of 5 years warranty on the compressor. Call **ColdTech Commercial** directly for repairs & service 24/7/365. It's the best warranty in commercial refrigeration.
- We make it easy. Recessed door handles for easy cleaning, compressor for easy access, auto-defrost, & free standing with four, black casters for easy moving.
- Three movable, plastic coated, steel shelves holding up to 60 kg/132.3 lbs each.

## Stainless Steel Three Door Pizza Prep Table CPT242-92



## Features:

- Large total capacity of 31 cu. ft./878 L to get the maximum amount of refrigerated storage space.
- Ventilated cooling system.
- North American standard safety & sanitation.
- Stainless steel drip tray under the evaporator.
- Net weight: 216 kg/476.2 lbs & Gross weight: 296 kg/652.6 lbs.
- Efficient condenser and evaporator made from copper piping with aluminum fin for faster cooling and superior efficiency.
- Housing and liner material are durable, food safety friendly, high quality, 300 series stainless steel.
- Temperature ranges from  
1° C to 6° C/33° F to 43° F
- Cutting Board (W x H x D) 91 ½" x ¾" x 19 ½"  
2324 mm x 19 mm x 496 mm
- Pans (lids): 12 stainless steel X ⅓



Watch Our Videos Online:  
[ColdTechCommercial.com/Videos](http://ColdTechCommercial.com/Videos)

## Stainless Steel

Solid, Durable high grade, 300-series, interior and exterior

## Warranty

3 Years bumper to bumper & a total of 5 years warranty on the compressor

## Digital Display

Digital temperature controls on the outside of the unit for easy programming

ColdTechCommercial.com  
Toll free: 1-855-241-3251 FAX: 1-877-298-8278  
email: [info@coldtechcommercial.com](mailto:info@coldtechcommercial.com)





# ColdTech – Culinary Coolness

## Specifications:

Voltage: 115 volts/20 amp circuit  
 Amperage: 10.5 amps/875 W  
 Compressor Power: 673 W  
 Free Standing  
 Gross Capacity: 31 cu. ft./878 L  
 Condiment Storage Capacity:  
 6.9 cu. ft./196 L  
 Refrigerator Capacity:  
 24.1 cu. ft./682 L  
 Refrigerant Type:  
 CFC Free R134a  
 Blowing Agent:  
 CFC Free polyurethane  
 Temperature Range:  
 • 1° C to 6° C  
 • 33° F to 43° F  
 Thermostat/Temperature Display:  
 Digital  
 Doors: Self closing, recessed  
 handles, 300 series stainless steel  
 Shelving: Plastic coated steel holds  
 up to 60 kg/132.3 lbs  
 Casters: 4  
 Cord Length: 112 3/16"/2850 mm  
 Unit Dimensions (W x H x D):  
 2334 mm x 1088 mm x 800 mm  
 91 7/8" x 42 13/16" x 31 1/2"  
 Carton Dimensions (W x H x D):  
 2465 mm x 1165 mm x 930 mm  
 97 1/16" in x 45 7/8" x 36 5/8"  
 Shipping Cube:  
 94.29 cu.ft./2.67 cbm  
 Net Weight: 216 kg /476.2 lbs  
 Gross Weight: 296 kg /652.6 lbs

## Stainless Steel Three Door Pizza Prep Table CPT242-92

### Elevation:

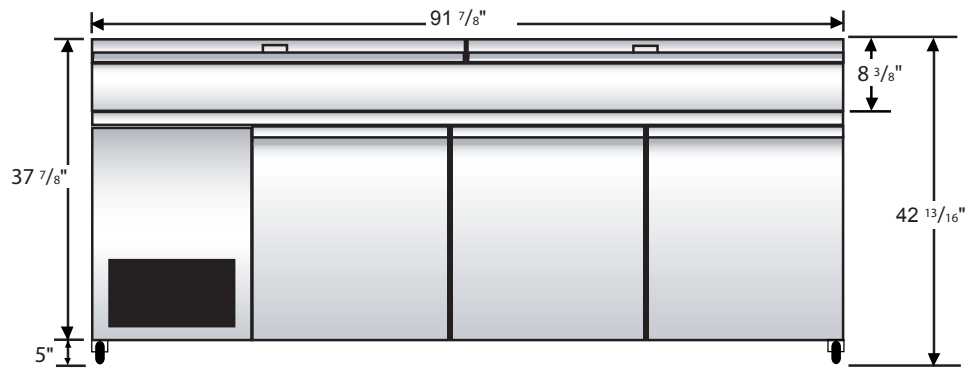

### Top View:

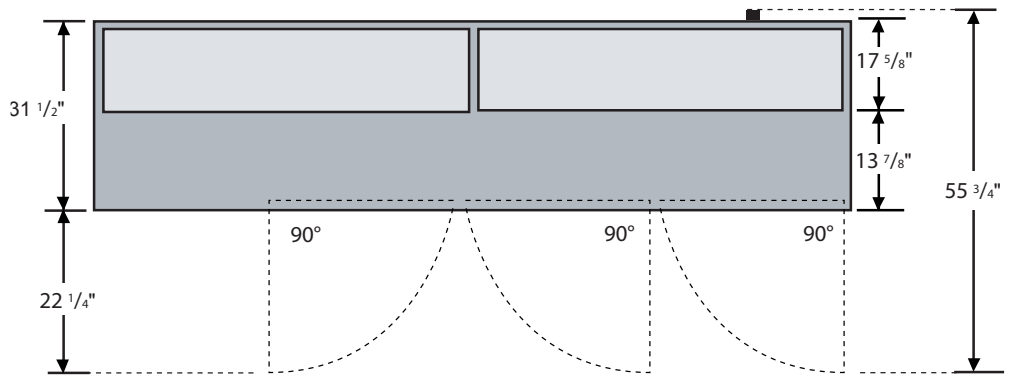

Plug:



Certifications:



Specifications subject to change without notice. 070811

ColdTechCommercial.com  
 Toll free: 1-855-241-3251 FAX: 1-877-298-8278  
 email: info@coldtechcommercial.com

